



# Pharmacy Vaccine Refrigerators

## *User Manual & Setup Guide*

**TPR RANGE**

*Dixell XR70*

---

**ABN:** 80 000 859 129  
**Head Office:** 10-12 Ross Place  
Wetherill Park NSW 2164 Australia

**Phone:** +61 2 9604 3911  
**Email:** [hello@thermoline.com.au](mailto:hello@thermoline.com.au)  
**Web:** [www.thermoline.com.au](http://www.thermoline.com.au)

---

# Contents

<b>General Information</b>	<b>4</b>	<b>Troubleshooting</b>	<b>24</b>
<b>Product Specifications</b>	<b>5</b>	Technical and Repair Support	24
<b>Operating Environment</b>	<b>9</b>	<b>Warranty</b>	<b>25</b>
Cabinet Location	9		
Bench Top Location	9		
Electrical Connections	10		
<b>Setup</b>	<b>12</b>		
Uncrating/Unpacking	12		
Moving the Refrigerator	13		
Castors	13		
Refrigerator Location	14		
Shelves	15		
Cleaning	16		
Door Gasket	17		
Loading	18		
Port Hole	18		
<b>Start Up Procedure</b>	<b>19</b>		
Start Up Procedure	19		
<b>Dixell User Guide</b>	<b>20</b>		
On Screen Alarms	20		
Temperature Logging Min/ Max	21		
Calibration	21		
Set Point	21		
Low Temperature Protective Cutout (LTPC)	22		
Chart Recorder	22		
BMS Output	23		



**General  
Warning Sign**

**Warning sign:** signifies a general warning, and indicates a risk to people specified by the supplementary sign that if not avoided, may result in death or serious injury.



**Warning;  
Flammable**

**Warning; Flammable:** signifies a flammable warning, and indicates a risk of flammable content as specified by the supplementary sign that if not avoided, may result in a fire by igniting flammable material.



**Warning;  
Electricity**

**Warning; Electricity:** signifies a electricity warning, and indicates a risk of contact with electricity as specified by the supplementary sign that if not avoided, could result in injury.



**Warning; Hot  
Surface**

**Warning; Hot Surface:** signifies hot surface warning, and indicates a risk to people specified by the supplementary sign that if not avoided, will result in contact with hot surface.



**General  
Prohibition Sign**

**General Prohibition:** signifies a prohibited action, indicates a risk to people specified by the supplementary sign that if not avoided, will result in death or serious injury.



**Do Not Expose  
Outside**

**Do Not Expose Outside:** signifies prohibiting the exposure to direct sunlight, and indicates a raised temperature due to sunlight or placement on hot surface can cause harmful damage to cabinet.

**This user manual is intended for Thermoline's Pharmacy Vaccine Refrigerator. We recommend that you read this user manual the whole way through before you start using the cabinet. Consider this manual as a part of the cabinet and an integral part to its function. We recommend keeping it close and within easy access.**

The Thermoline Pharmacy Vaccine Refrigerator 145, 200, 520, 950 and 1500 models are designed and manufactured to provide safe and precise temperature conditions for the items stored inside. Designed to operate at +5°C, with alarms set at 2°C and 8°C, the Thermoline Pharmacy Refrigerators offer an industry standard in forced draught refrigeration.

The Thermoline Pharmacy Vaccine Refrigerator is set to function with specific operating ranges. The optimum operating conditions will be explained further in this manual.

- Control Stability: +/- 0.5°C
- Operating Temperature fixed at +5°C



# Product Specifications

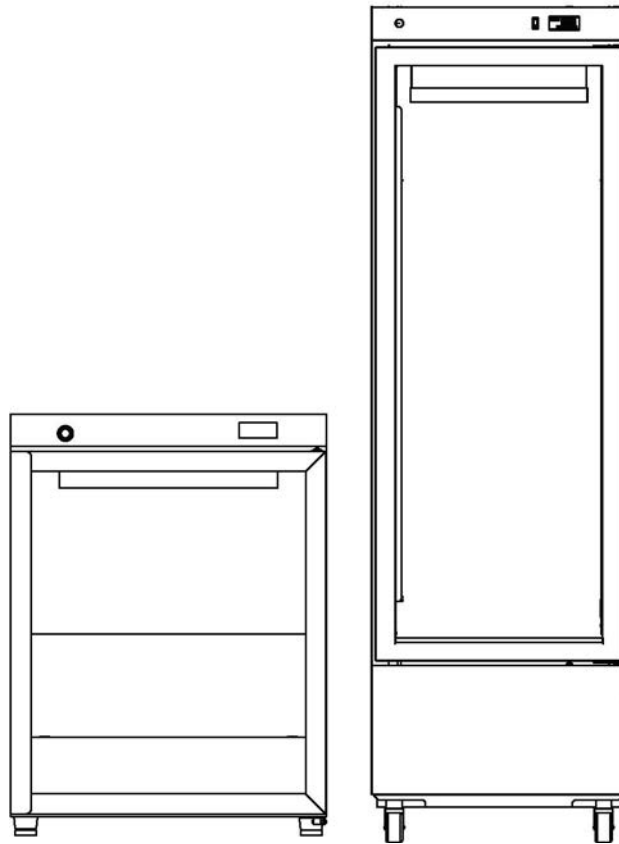

## Dimensions

### External

TPR-145-1-(GD/SD)

TPR-200-1-(GD/SD)

WxDxH (mm)

600x600x800

560x580x1590

### Internal

WxDxH (mm)

530x430x620

440x420x1080

## Spacing

TPR-145

TPR-200

Front (mm)

600

560

Back (mm)

100

Sides (mm)

100

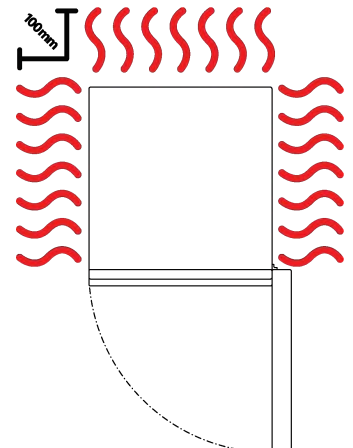

# Product Specifications

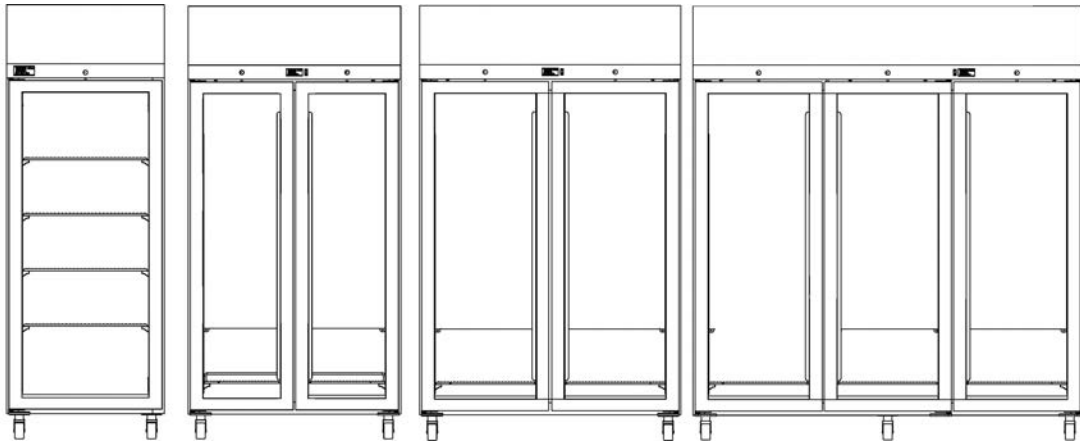

## Dimensions

External	TPR-520-1-(GD/SD)	TPR-750-2-(GD/SD)	TPR-950-2-(GD/SD)	TPR-1500-3-(GD/SD)
WxDxH(mm)	740x740x2010	1010x740x2010	1230x740x2010	1830x740x2010

## Internal

WxDxH(mm)	590x530x1430	850x530x1430	1080x530x1430	1680x530x1430
-----------	--------------	--------------	---------------	---------------

## Clearance

	TPR-520	TPR-750	TPR-950	TPR-1500
Front (mm)	740	500	610	610
Back (mm)	100			
Sides (mm)	100			

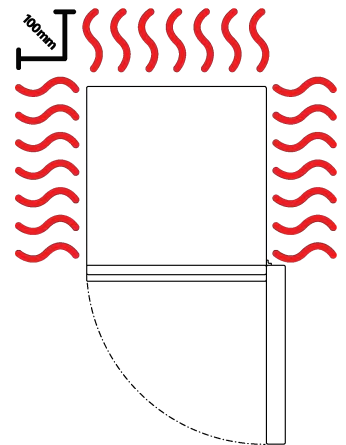

# Product Specifications

## Technical Specifications

	TPR-145	TPR-200
Temperature Range	+2°C to +8°C	
Temperature Control Stability	+/- 0.5°C	
Temperature Uniformity	+/- 2.0°C	
Electrical	0.9A/230V	2.5A/230V
Nominal Capacity	145L	200L
Weight	65kg	90kg
Heat Output (Watts)	240	300
Noise Level @ 1 metre (dbA)	40	53
Power Consumption (kWh/24)	1.5	3.6
Refrigerant Type	R134a	

	TPR-520	TPR-750	TPR-950	TPR-1500
Temperature Range	+2°C to +8°C			
Temperature Control Stability	+/- 1.0°C			
Temperature Uniformity	+/- 2.0°C			+/- 2.5°C
Electrical	2.8A/230V	3.8A/230V	3.8A/230V	5.4A/230V
Nominal Capacity	520L	750L	950L	1500L
Weight	160kg	190kg	220kg	290kg
Heat Output (Watts)	490	850	850	1050
Noise Level @ 1 metre (dbA)	64	67	67	67
Power Consumption (kWh/24)	4.4	6.0	6.0	8.5
Refrigerant Type	R134a			

## Product Specifications

<b>Features</b>	<b>TPR-145</b>	<b>TPR-200</b>	<b>TPR-520</b>	<b>TPR-750/950</b>	<b>TPR-1500</b>
Shelves (max @100mm spacing)	4 (max 4)	5 (max 6)	4 (max 11)	4 levels (max 11)	4 levels (max 11)
Castors	X	Rear Rollers	✓	✓	✓
Porthole Diameter	13mm				
Internal Fan	✓	✓	✓	✓	✓
Door Locks	✓	✓	✓	✓	✓
BMS Plug	✓	✓	✓	✓	✓
Ecofoam Insulation	✓	✓	✓	✓	✓
<b>Safety</b>					
Over Current Protection	✓	✓	✓	✓	✓
Over Temperature Safety	✓	✓	✓	✓	✓
<b>Options</b>					
Glass or Solid Doors	Nomenclature designations: Glass Door (GD), Solid Door (SD)				
LTPC: Low Temp Cut Out	Low Temperature Protection Cut Out. This option is designed to prevent products inside the fridge from freezing (extremely important for the storage of vaccines).				
Chart Recorder	7 Day Chart Recorder with Battery Backup 145L/200L: Flying Lead, 520L-1500L: Built into top panel				
Additional Port Holes	Additional 13mm port holes or 50mm port holes can be added to the side walls				
Stainless Exterior	X	X	✓	✓	✓



## Cabinet Location

Please ensure the refrigerator is placed in the right environment, away from direct sunlight or direct heat sources (Fig 1). The product shouldn't be placed in a room where the ambient temperature exceeds that of which it was designed to operate.

The refrigerator should be stored inside at all times. Failure to adhere to this could cause significant drops in cabinet performance and damage to items stored inside.

### Extreme Operating Environment:

- **Temperature:** 10°C to 32°C
- **Humidity:** Up to 85%RH

### Optimal Environment:

- **Temperature:** 23°C (+/-2.0°C)
- **Humidity:** 50%RH (+/-5%RH)

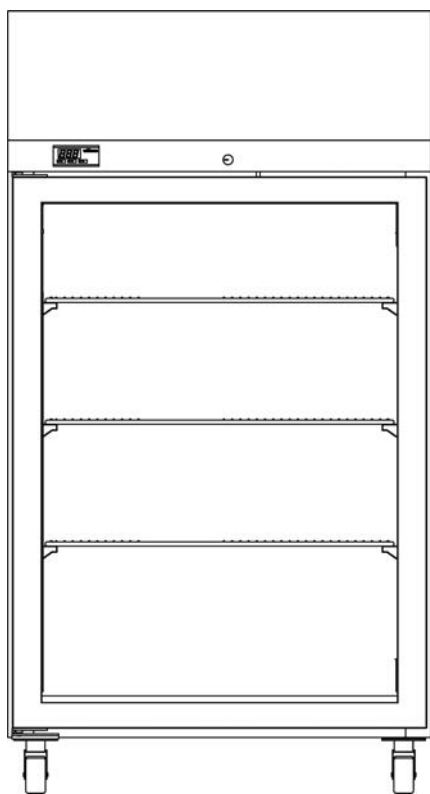

Fig 1. Suitable Environment

## Bench Top Location

Only the TPR-145-GD/SD can be placed on a bench or plinth due to the size of the other models.

### Installation Requirements:

- Under no circumstances should any refrigerators be stacked on top of each other (Fig 2).
- 145 Cabinets come with adjustable feet in case of uneven surfaces (Fig 3).

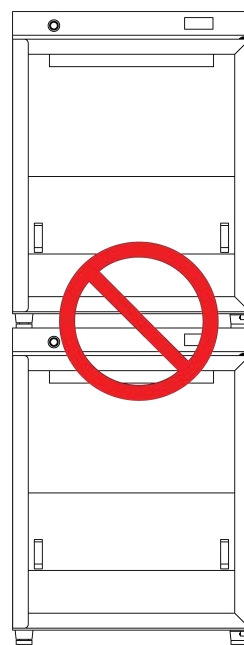

Fig 2.

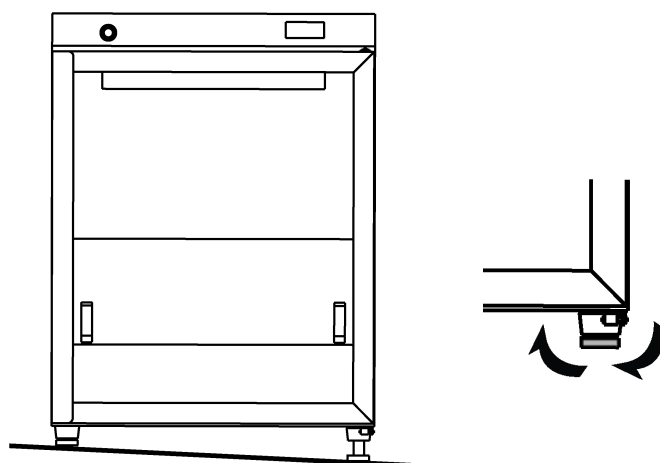

Fig 3.

# Operating Environment

## Electrical Connections

The refrigerator is suitable for connection to a standard 10 amp, 230 volt, 50Hz supply. A dedicated outlet should be used for the supply. Do not use power boards or the like.

### Electrical:

- The refrigerator includes an approx. 2.5m fixed mains power lead with a three pin plug. Ensure the product is reasonably distanced from the power supply. (Fig 1)

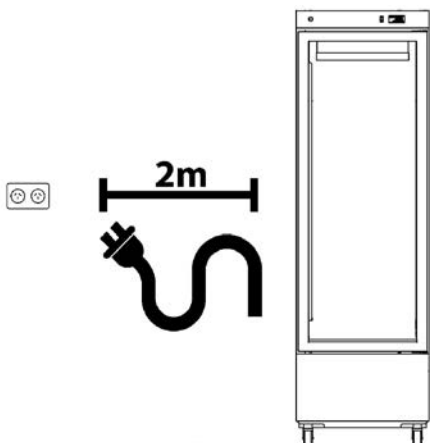
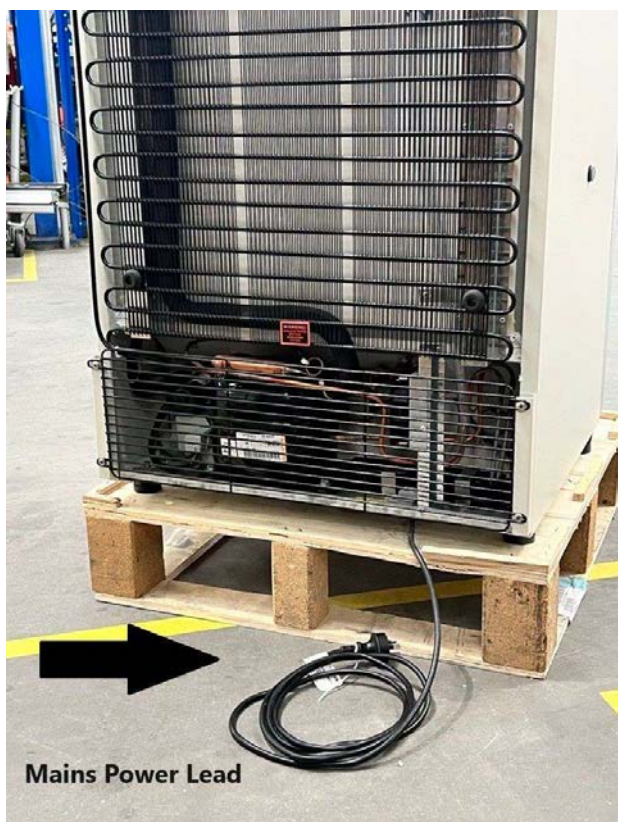

Fig 1. Suitable distance from power supply (2m)



Mains power lead location for 200 refrigerator.



Mains power lead location for 145 refrigerator.

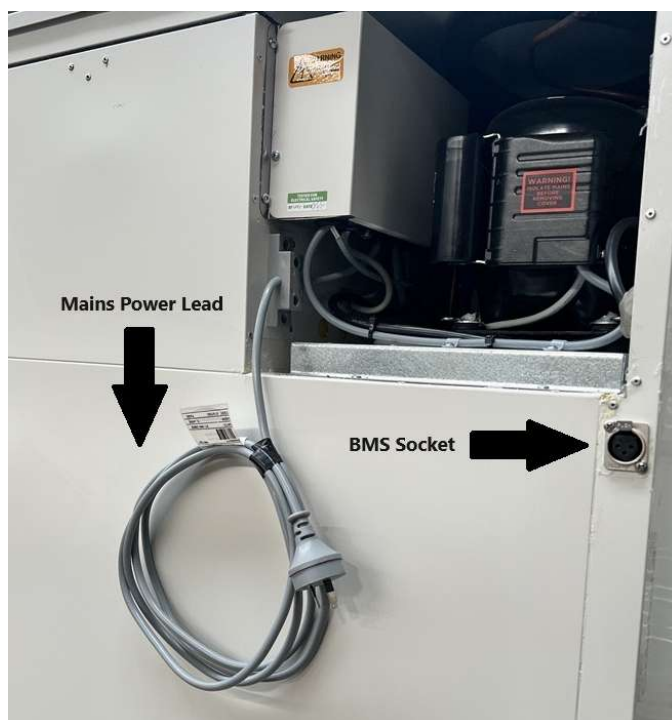

Mains power lead location for 520, 750, 950 and 1500 refrigerator.

## Operating Environment Warnings

---



The refrigerators require an even surface to ensure consistent performance. Internal contents can also be damaged by the cabinet being on an uneven surface.

The refrigerator require ventilation around them. 100mm on either side and the back is required.

The refrigerator should be stored inside at all times. Failure to adhere to this could cause significant drops in cabinet performance and damage to items stored inside.



These refrigerators are not suitable for use with flammable solvents! They are fitted with components that may be the source of ignition.

## Uncrating/Unpacking

### Unpacking process for foam wrapped and crated:

- In most cases, the refrigerator will be delivered foam wrapped and on its castors via sensitive freight. The 145 and 200 refrigerator will be delivered in a box on a skid.
- The refrigerator may be delivered to remote areas in a crate. To remove the crate packaging that comes with some cabinets, unscrew both the left and right sides of the packaging. A forklift is needed to remove the refrigerator from the crate.
- Please don't dispose of the packaging until the refrigerator is inspected. If damage is present upon opening your package, notify your supplier or Thermoline without delay on +61 2 9604 3911 or email at [service@thermoline.com.au](mailto:service@thermoline.com.au).

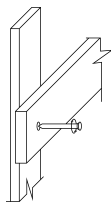
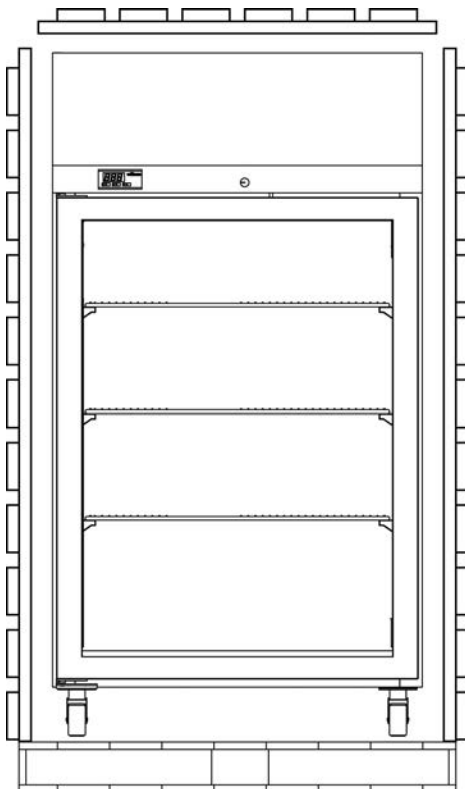

**Unpacking Process (crated)**



**Unpacking Process (foam wrapped)**

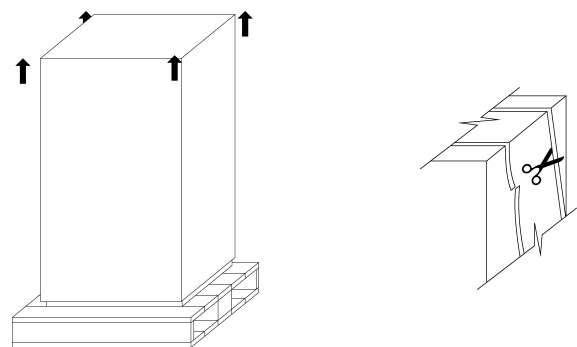

**Unpacking Process (Box and Skid)**

## Setup

### Moving the Refrigerator

#### Moving the Refrigerator:

- Ensure that the refrigerator is rolled on an even and flat surface. Uneven surfaces can cause the refrigerator to fall over.

**NOTE:** Refrigerators are 'Top Heavy'. Do not move the cabinet too quickly.

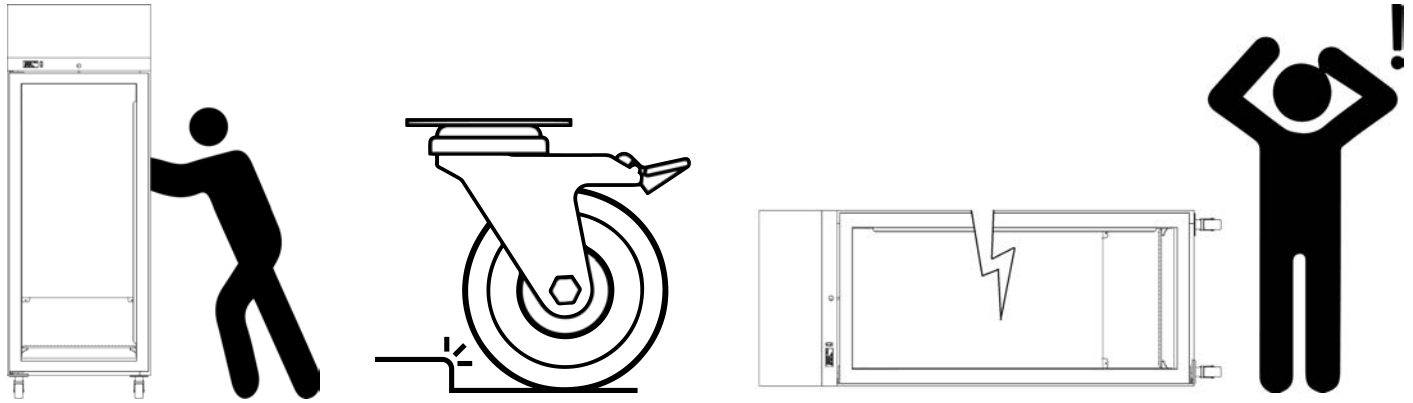

Safe moving of cabinet.

Castor catching causing the cabinet to topple.

### Castors

The refrigerators are equipped with lockable castors to prevent cabinet movement.

#### Castor Setup:

- Please make sure that the refrigerator is placed on an even and flat surface. Uneven surfaces can cause issues within the cabinet. Uneven surfaces can cause the cabinet to fall over or roll away with unlocked castors.
- Castors can be fixed in place by pushing down on the brake lever. Ensure the castors are locked to prevent unwanted movement from the refrigerator (**Fig 1**).
- Please ensure when placing the refrigerator into place that the castors can be accessed so they can be locked (**Fig 3**) and unlocked (**Fig 2**). Please get in touch with your supplier or Thermoline should there be any castor damage.

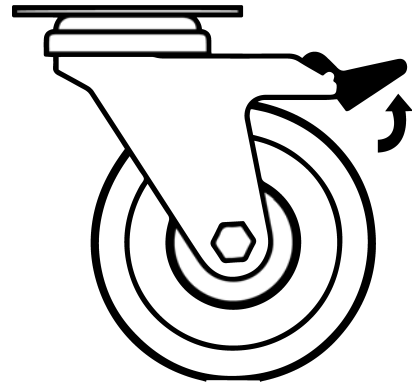

Fig 2. Castor Unlocked

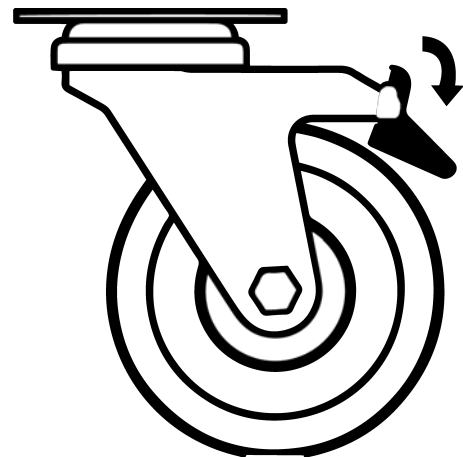

Fig 3. Castor Locked



Fig 1.

# Setup

## Refrigerator Location

### Location Requirements:

- The refrigerator requires to be on a flat level surface. (Fig 1)
- Do not store items on top of the refrigerator.
- The refrigerator generates heat as part of its regular operation. Thermoline suggests at least 100mm on the sides and back and 300mm above the cabinet to aid accessibility and heat dissipation. (Fig 2)
- The refrigerator door should also be allowed to open and close at full range. (Fig 3)

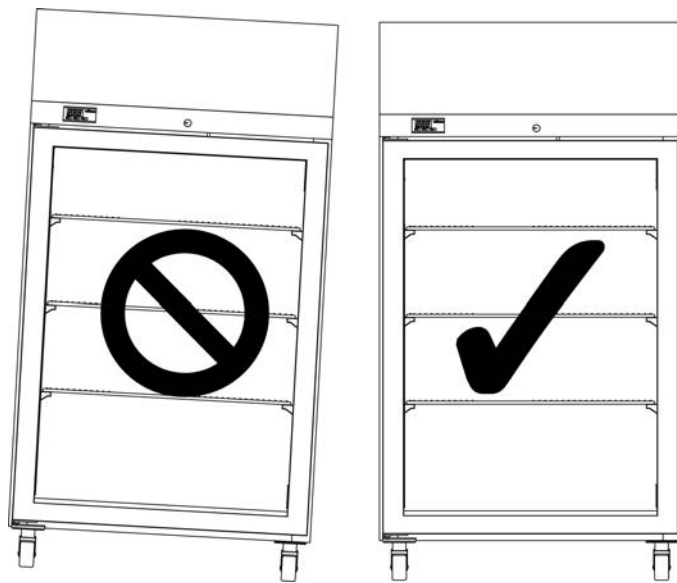
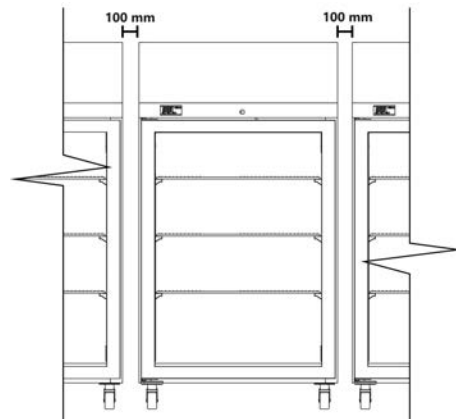

Fig 1. Correct Levelling

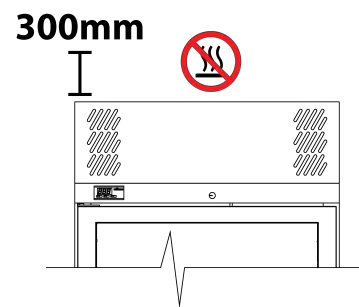

Fig 2.

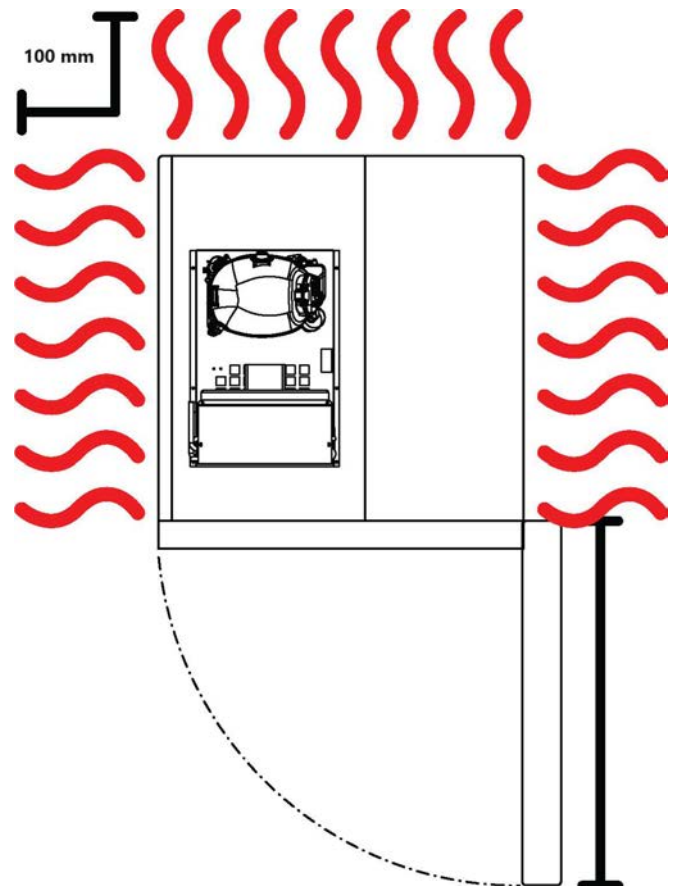

Fig 3.

## Setup

---

### Shelves

All refrigerators come equipped with shelves used for holding items while in operation. The shelves can be adjusted to different heights to accommodate other size items.

#### To adjust the shelf clips you must:

- Hook the top of the clip into the slot seen above.
- Pinch and squeeze the base of the clip
- Push base of clip into slot and release.
- To remove, repeat process.

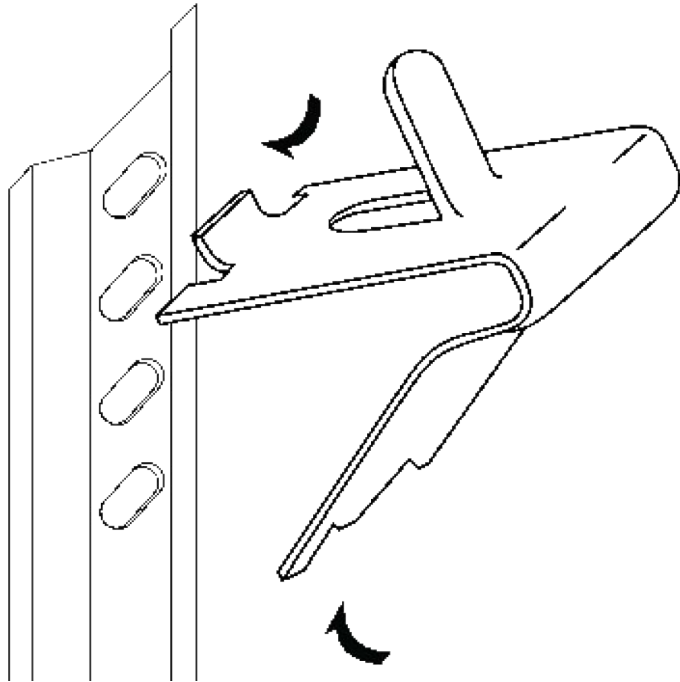

#### Shelving:

- All refrigerators are supplied with adjustable shelf clips to accommodate different size items within the cabinet; the amount of shelf clips supplied changes depending on the size of the cabinet ordered. Please see the refrigerator specifications for the number and maximum number of shelves.



#### NOTE:

- The edges of the clips can be sharp. Extreme care should be taken when adjusting the clips.

# Setup

## Cleaning

The interior, exterior, and door gasket can be cleaned as often as required using a soft cloth and soapy water. Never use abrasive cleaners or scouring pads, as these will scratch the surface and may result in corrosion. Never use caustic-type cleaning agents.



All cabinets have electrical components. These items should not be subjected to any levels of moisture.

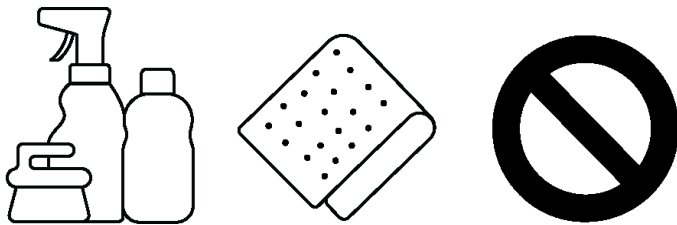

### Cleaning the Condenser:

- Turn off power at the power point before cleaning the condenser.
- The condenser is located on the left-hand side of the cabinet behind the front panel (**Fig 1**). To remove the front panel, lift it up to free it from the locating blocks. Once free, pull the panel carefully forward and away from the refrigerator to have full access to the condenser and would be able to clean it.
- **NOTE:** Use a soft brush and/or vacuum with a soft brush attachment to remove any lint and dust build-up (**Fig 2**), taking extreme care not to damage the aluminium fins on the condenser face. Never blow air into the condenser.

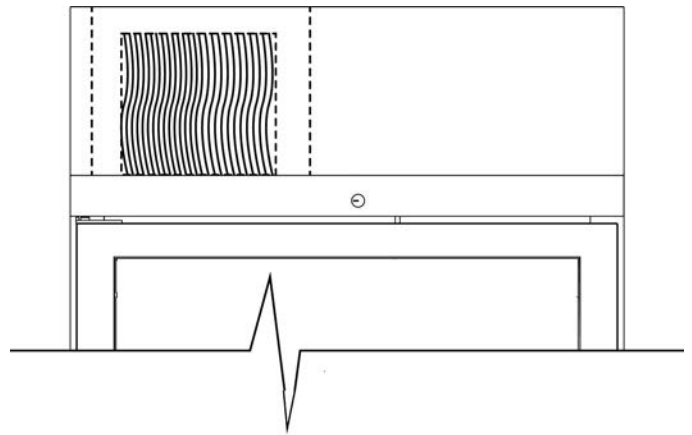

Fig 1: Location of Condenser

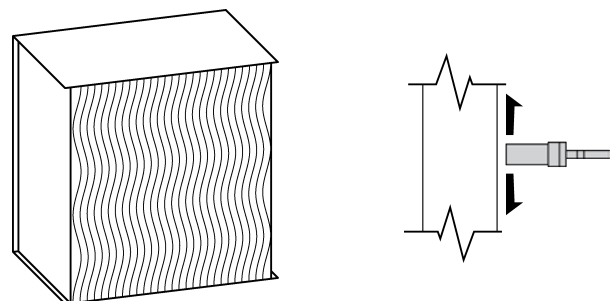

Fig 2.



## Setup

---

### Door Gasket

The door gasket should be cleaned regularly with a mild soap solution. If a gasket is to be replaced, please get in touch with Thermoline. Regular inspection is recommended.

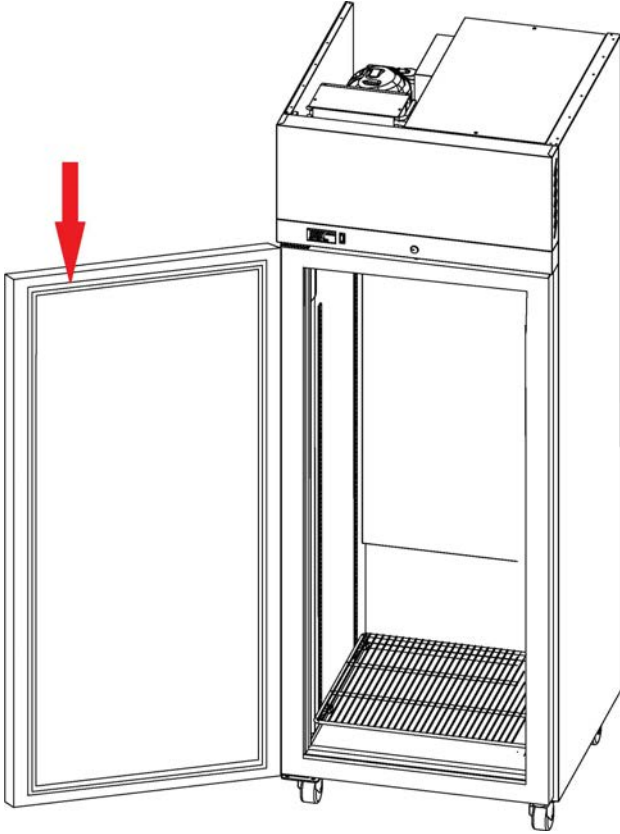

### Setup Warnings

---



Castors can be fixed in place by pushing down on the brake lever. Ensure all castors are locked to prevent unwanted movement from the cabinet.

Ensure that the refrigerator is rolled on an even and flat surface. Uneven surfaces can cause the cabinet to fall over and damage the product.



Packaging supplied on cabinets can be sharp and cause injury. Caution must be taken when removing the crate or using knives to cut tape and cardboard.

## Setup

### Loading

The refrigerator requires air movement throughout the chamber to hold temperature and to bring new samples to temperature. Correct loading will ensure the most efficient cabinet performance.

#### Loading Requirements:

- Distribute the load evenly over all the shelves rather than stacking everything on one shelf. This is to ensure unobstructed airflow throughout the chamber.
- Do not load samples on the floor of the refrigerator.

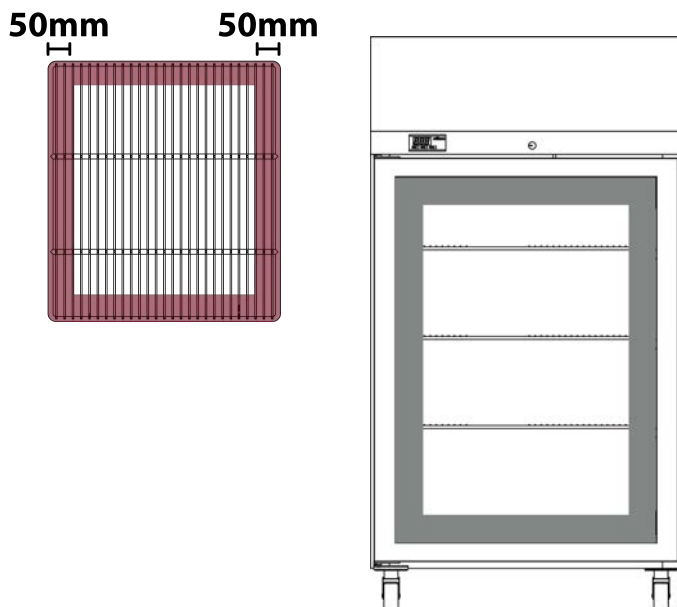

Please ensure that the highlighted areas are free to allow air to pass and that the samples on the shelves allow air to pass between them.

### Port Hole

The port hole can be found on the left side of the refrigerator as you look at it. The cabinet comes equipped with a plug that may be removed by simply pulling it out. Keep the plug safe in case the port hole needs to be closed again.

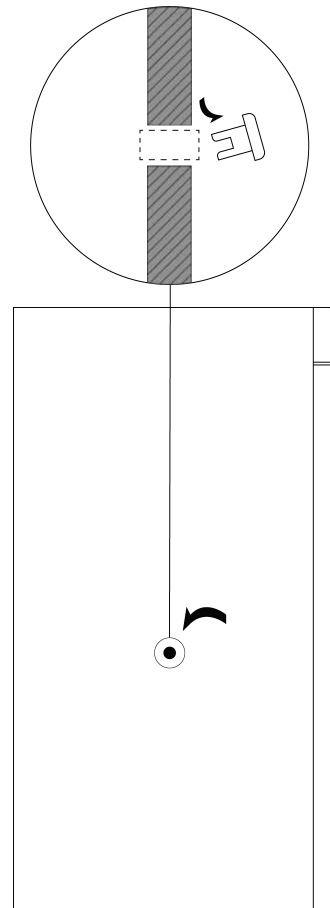

## Start Up Procedure

### Start Up Procedure:

- Locate the cabinet as previously described, and plug the mains lead into the power supply but do not turn the power on just yet.
- The cabinet is supplied with the shelves fixed in place. Adjust the shelf positions to suit your storage needs by moving the support clips provided.
- Turn on the power and circulating fan inside the cabinet will start immediately. You should also be able to turn on the internal light using the "light" switch on the front panel. Note: if the cabinet has been moved allow 20 minutes before turning it on.
- After a short warm-up period, the temperature control will display the temperature inside the refrigerator. The refrigeration compressor will start after a few minutes.
- Allow the cabinet to reach operating temperature and to operate for at least 8 hours prior to loading stock.

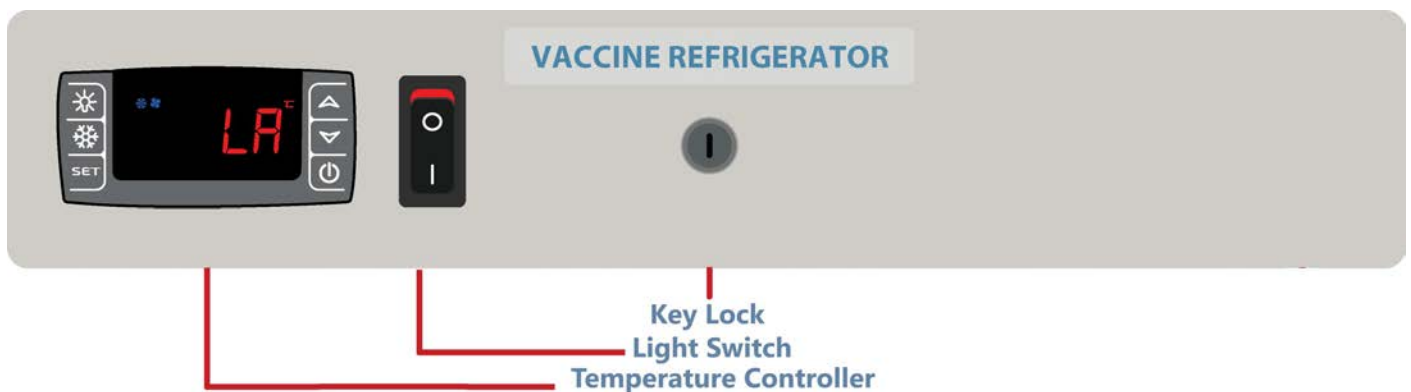
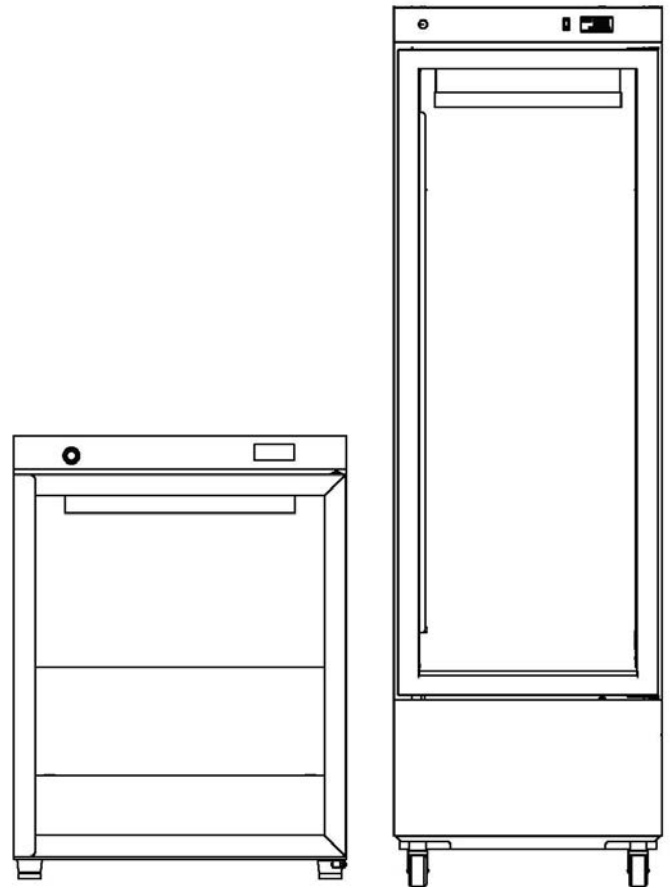

The Dixell XR70 Controller is a microprocessor based controller suitable for applications on medium or low temperature refrigerators, with relay outputs that control the compressor, fan and defrost. The temperature control has been factory set to operate at 5°C. The alarms are set to operate at 2°C for the low alarm and 8°C for the high alarm. Any button can be pressed to mute the alarm. Once muted, the alarm will resound in 15 minutes if the alarm conditions are still occurring.



**SET**

*Set:* To display the target set point; in programming mode, it selects a parameter or confirms an operation. The set point is fixed on all TPR refrigerators.



*Power Button:* Not Used



*Increase Button:* To see the maximum stored temperature; in programming mode, it browses the parameter codes or increases the displayed value.



*Decrease Button:* To see the minimum stored temperature; in programming mode it browses the parameter codes or decreases the displayed value.



*Defrost:* Not Used



*Light:* Not Used

LED	Mode	Function
	On	Compressor Running
	Flashing	Compressor off during door opening
	On	Fans Enabled
	Flashing	Fans off during door opening
	On	Not Used
	Flashing	Not Used
	On	An alarm is occurring

## On Screen Alarms

Message	Cause	Explanation / Action
P1	Probe 1 Failure	Call Service
P2	Probe 2 Failure	Call Service
HA	High Alarm - Product Temperature	Probe in bottle is above alarm point
HA2	Possible probe fault	Call Service
LA	Low Alarm - Product Temperature	Probe in bottle is lower than alarm point
LA2	Low temperature entering the cabinet	Possible air blockage in cabinet
DA	Door Open Alarm	Door not closed securely
PoF	UP & DOWN buttons pressed simultaneously	Press UP & DOWN buttons simultaneously until 'PoN' appears

## General Controls

---

### Temperature Logging Min/Max

The digital temperature control has a feature that allows the operator to log or record the maximum and minimum temperatures attained over a period of time. These logged temperatures can be reset by simply pressing the buttons on the face of the instrument as follows:

**How to:** see the minimum temperature

- Press and release the DOWN key.
- The "Lo" message will be displayed, followed by the minimum temperature recorded.
- By pressing the DOWN key again or by waiting 5 seconds, the normal display will be restored.

**How to:** see the maximum temperature

- Press and release the UP key.
- The "Hi" message will be displayed, followed by the maximum temperature recorded.
- By pressing the UP key again or by waiting 5 seconds, the normal display will be restored.

**How to:** reset the maximum and minimum temperature

- While the max or min temperature is displayed, press and hold the SET key for 3 seconds until "rSt" is displayed.
- To confirm the operation, the "rSt" message will start blinking, and the normal temperature will be displayed.

### Set Point

The set point is fixed at 5°C for the Vaccine/Pharmacy refrigerator.

If your wish is to just view the set point. Simply press the **SET** button.

Press **SET** = View Set Point Value.

### Calibration

Calibration of the unit ensures correct product temperature and optimal freezer performance. Calibration should be done by a trained technician.

Press and hold the **SET and DECREASE buttons** simultaneously. The following parameters will be available:

**Ot** - Sensor Offset in Bottle  
**OE** - Return Air Sensor Offset  
**O4** - Low Temp Alarm Sensor Offset  
**dP1** - Current Temperature of the Bottle Sensor  
**dP2** - Current Return Air Temperature  
**dP4** - Freeze Protection Alarm

Calibration is usually performed at 5°C for refrigerators. This procedure is a standard procedure used by Thermoline. The aim when calibrating a refrigerator is to have the bottle at 5°C. This is achieved by placing a reference sensor in the bottle, or in a bottle adjacent to the units bottle, and noting the indicated temperature. The **OE** parameter is then adjusted to increase or decrease the air temperature until the reference sensor reads 5°C. Once the reference sensor has an average temperature of 5°C, adjustments to **Ot** are made so that **dP1** (Display Temperature) equals 5°C.

**NOTE:**

- High temperature alarm set at 8°C
- Low temperature alarm set at 2°C
- Refrigerator operating temperature set at 5°C

## General Controls

### Low Temperature Protective Cutout (LTPC)

As an added safety feature, the refrigerator can be factory fitted with a low temperature protective cutout, which is factory set and not adjustable, to stop the temperature inside the refrigerator from falling below 0°C. This is particularly important in the storage of vaccines, which can be destroyed if frozen. The cutout operates independently from the temperature control and turns off the compressor at +1°C to +2°C. In this way, should the controls fail in a "cooling" condition, the product will be protected against freezing.

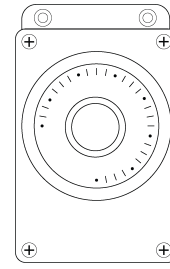

For testing and calibration of the LTPC, contact your service technician.

The LTPC is factory set (held in place with silicone added at the factory). There is no requirement to adjust this.

### Chart Recorder



A circular chart recorder can be factory fitted as an optional extra. The recorder has a seven day chart with a battery back-up that will keep the chart running for at least 24 hours in the event of a power failure.

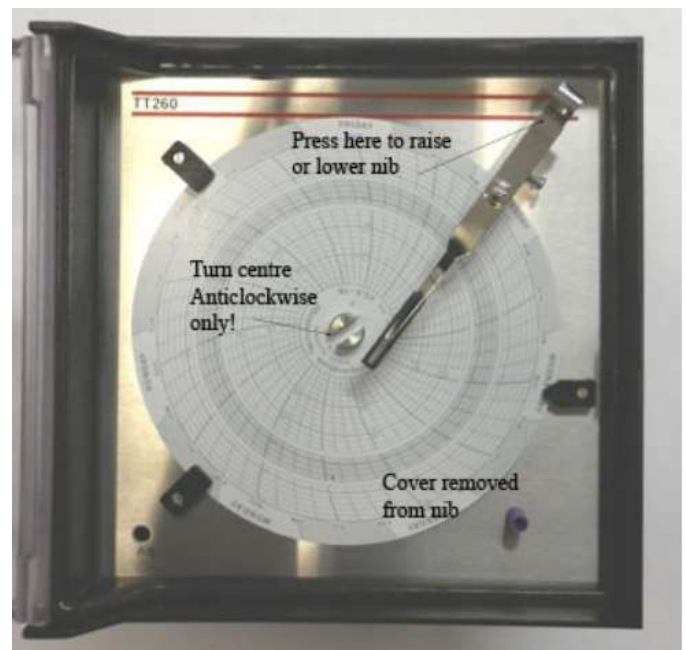

#### Setting Time

Set the time on the Chart Recorder by:

- Unlock the door using the key supplied.
- Raise the nib off the chart paper by pushing the lever at the top right corner.
- With the pen nib lifted off the paper, use a flat blade screwdriver or similar into the slot in the centre and turn it **ANTICLOCKWISE ONLY**.
- Lower the nib onto the chart and close the clear door, then locking with the key provided.

#### Replacing Chart Papers

- Unlock the recorder door using the key supplied.
- Raising the nib off the paper by pushing the lever at the top right corner.
- Replace the chart paper by pulling the edges of the chart out from under the 3 locating tabs.
- Put the new chart paper over the slot in the spindle trying not to tear the chart as you do it.
- Fit the outer edges of the chart back under the locating tabs to keep it in place.
- Lower the nib onto the chart by pushing on the lever again.
- Close the door then locking with the key provided.

## General Controls

### BMS Output

This cabinet is fitted with a 3-pin socket to allow for connection to a building monitoring system or phone dialler. A plug is also supplied separately to connect the socket to your wiring.

The alarm contacts have no voltage present, but we recommend that the wiring is connected by a suitably qualified technician.

**An alarm can be triggered by the following:**

- Loss of power
- High temperature inside cabinet (8°C )
- Low temperature inside cabinet (2°C )
- Door Alarm

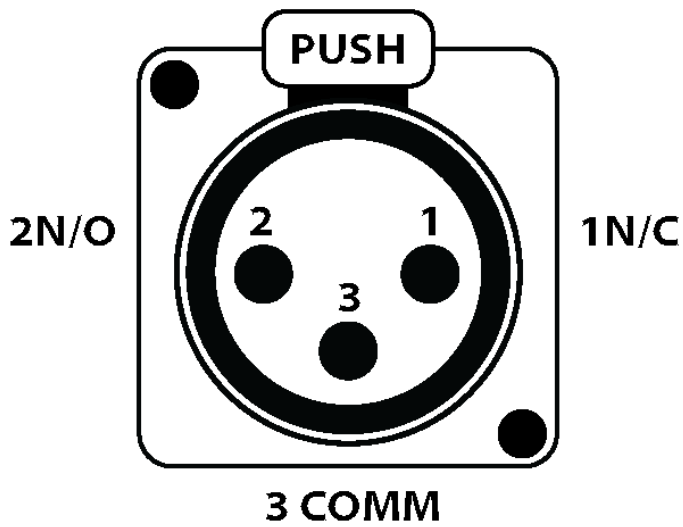

**1N/C:** Will open loop upon alarm situation. This is the optimal option.

**2N/O:** Will close loop upon alarm situation.

**3COMM:** At least one wire in connected to this pin.



Location of BMS socket (145L)



Location of BMS socket (200L)

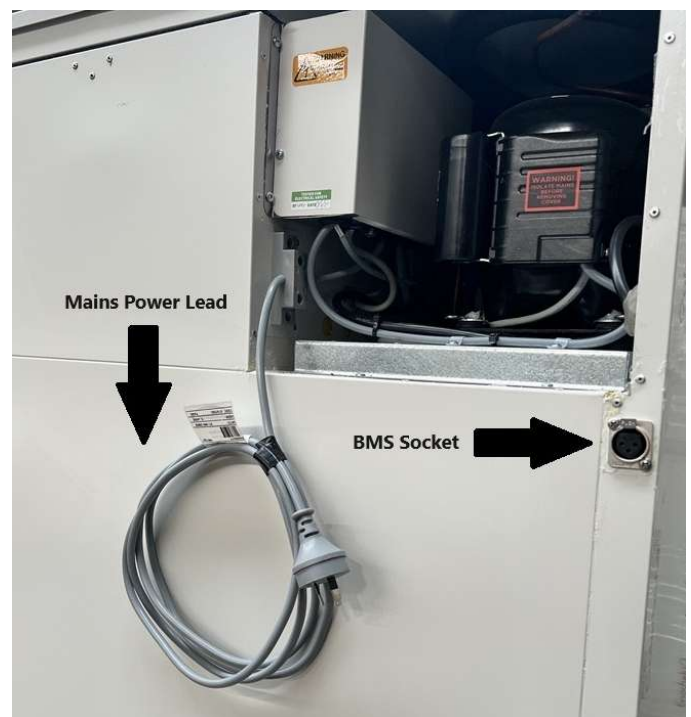

Location of BMS socket for the 520, 750, 950 and 1500

Problem	Fix
<p><b>Temperature of Fridge running warmer than expected.</b></p>	<p><b>Condenser</b> Condenser could be dirty and contain blockages. Clean condenser as described within manual. Ensure there is enough air space around the fridge.</p> <p><b>New Items in Fridge</b> Have you put new pharmaceuticals in the fridge - Allow about an hour to see if the temperature comes down</p> <p><b>Air Flow</b> Is the air flow in the fridge blocked - Ensure the stock is evenly distributed.</p> <p><b>Offset Incorrect</b> Air temperature offset may be required to be adjusted.</p>
<p><b>PoF is shown on the Dixell Controller.</b></p>	<p><b>Locked Controller</b> The message PoF means the controller is locked. Please press the <b>UP &amp; DOWN</b> buttons simultaneously until '<b>PON</b>' appears.</p>
<p><b>The controller is showing HA2 Alarm.</b></p>	<p>More often than not, the HA2 alarm is a nuisance alarm and can be adjusted to prevent it from appearing. It can also mean the temperature inside the fridge has gone high or possibly due to a faulty sensor.</p>
<p><b>LA2 Alarm is shown on the controller.</b></p>	<p><b>Airflow</b> Ensure even airflow and the drugs are evenly spread out through the fridge.</p>
<p><b>Condensation on the outside of the door.</b></p>	<p>Ambient Humidity is too high.</p>

## Technical and Repair Support

When contacting Thermoline regarding information about the product, it is important to have the Serial Number and other related information with you. The serial number is on a silver sticker, usually located near the power IEC socket.

Contact Thermoline service on +61 2 9604 3911 or email at [service@thermoline.com.au](mailto:service@thermoline.com.au)



Model:  
Serial No:  
Watts/Amps:  
Volts:

Phone: +61 2 9604 3911  
Email: [hello@thermoline.com.au](mailto:hello@thermoline.com.au)



**2**  
Years  
Warranty



***Have the following information available when you contact the service department. Model number and serial number. This is generally found on the exterior of the cabinet in the form of a stick-on label. The company name, address, contact name, contact phone number. A brief description of the problem. All warranty claims must be reported to, and agreed to by a Thermoline representative prior to any work being carried out.***

---

## Standard 24 Month Warranty

### ***Thermoline Scientific Equipment Pty Ltd ABN 80 000 859 129 ('Thermoline')***

Thermoline warrants to the original purchaser that this product will perform to its product specification for a period of 2 years from date of purchase, provided that the installation of the product has been carried out in accordance with the latest version of the manufacturer's instructions and further provided that the use of the product complies with that specified in the relevant specification. Thermoline is not responsible for any loss or damage arising from incorrect usage, usage outside the suitability of the product as stipulated in the manufacturer's instruction, damage caused by accident, fire, flood, act of God or failure to properly install, operate or maintain the goods in accordance with the printed instructions provided.

The following statement applies only to product sales that fall within the definition of a Consumer Sale set out in the Australian Consumer Law contained within the Competition and Consumer Act (Cth) 2012:

Our goods come with guarantees that cannot be excluded under the Australian Consumer Law. You are entitled to a replacement or refund for a major failure and for compensation for any other reasonably foreseeable loss or damage. You are also entitled to have the goods repaired or replaced if the goods fail to be of acceptable quality and the failure does not amount to a major failure. Notwithstanding the preceding clause and to the extent permissible by law, the liability of Thermoline is limited, in relation to the warranted product and at the option of Thermoline to:

Replacing the product or the supply of equivalent product;  
The repair of the product;  
The payment of the cost of replacing the product or of acquiring equivalent product; or  
The payment of the cost of having the product repaired.

To the extent permitted by law, all other warranties whether implied or otherwise, not set out in this Warranty are excluded and Thermoline is not liable in contract, tort (including, without limitation, negligence or breach of statutory duty) or otherwise to compensate the Purchaser for:

any increased costs or expenses;  
calibration/certification services;  
any loss of profit, revenue, business, contracts or anticipated savings;  
any loss or expense resulting from a claim by a third party.  
Any special, indirect or consequential loss or damage of any nature whatsoever caused by Thermoline's failure in complying with its obligations or the purchaser's failure due to accident damage, impact, misuse or negligence.

The benefits given to the purchaser in this Warranty are in addition to other rights and remedies under a law in relation to the products or services to which this warranty applies. This warranty applies only to products purchased and installed in Australia and does not cover any consumable items e.g. filters, light globes, ultrasonic nebulizers. The warranty does not extend to labour and freight costs where the warranted product is located outside Australia.

To make a warranty claim, contact Thermoline on 02 9604 3911 or [service@thermoline.com.au](mailto:service@thermoline.com.au).

# We are proudly Australian owned

We will continue to invest in Australian  
manufacturing.

